

Clarke®

air



WARNING: Do not use the compressor without reading this manual

OIL FREE AIR COMPRESSOR

MODEL NO: RANGER 7-260

PART NO: 2242030

OPERATION & MAINTENANCE INSTRUCTIONS



ORIGINAL INSTRUCTIONS

GC11/22 -rev 2

INTRODUCTION

Before you use this product, read this manual and follow the instructions carefully. In doing so you will ensure the safety of yourself and others around you, and you can also expect your purchase to give you a long and satisfactory service.

SPECIFICATIONS

Max Pressure	8 Bar/116 psi
Voltage	230 VAC (50 Hz)
Air Displacement	7.8 CFM
Receiver Capacity	24 L
Flow rate	220L/min
Ingress protection	IP20
Fuse Rating	13 A
Dimensions (L x W x H)	546 x 352 x 560 mm
Guaranteed Sound Power Level	96 dB(A)
Weight	22.7 kg

Please note that the details and specifications contained herein, are correct at the time of going to print. We reserve the right to change specifications at any time without prior notice.

GUARANTEE

This product is guaranteed against faulty manufacture for a period of 12 months from the date of purchase. Please keep your receipt which will be required as proof of purchase.

This guarantee is invalid if the product is tampered with in any way, or not used for the purpose for which it was intended.

Faulty goods should be returned to their place of purchase, no product can be returned to us without prior permission. This guarantee does not effect your statutory rights.

GENERAL SAFETY WARNINGS



WARNING: WHEN USING ELECTRICAL TOOLS, BASIC SAFETY PRECAUTIONS SHOULD ALWAYS BE FOLLOWED TO REDUCE THE RISK OF FIRE, ELECTRIC SHOCK AND PERSONAL INJURY

WARNING: READ ALL THESE INSTRUCTIONS BEFORE ATTEMPTING TO OPERATE THIS PRODUCT AND KEEP THESE INSTRUCTIONS IN A SAFE PLACE.

WORK AREA

1. **Keep the work area clean and well lit.** Floors should always be kept clear. Cluttered or dark areas invite accidents.
2. **Keep children and bystanders away while operating a compressor.** Distractions can cause loss of control.
3. The compressor should only be used in areas with adequate ventilation and should not be exposed to heat or used near flammable substances

PERSONAL SAFETY

1. **ALWAYS** stay alert, watch what you are doing and use common sense when operating the compressor. **DO NOT** use the compressor while you are tired or under the influence of medication, drugs or alcohol. A moment of inattention can result in personal injury.
2. **ALWAYS** use eye protection when operating compressed air equipment, and ensure that others in the work area are protected from flying particles from the front and from the side.
3. **ALWAYS** protect yourself against electric shock. **NEVER** operate the compressor in wet or damp locations.
4. **NEVER** over-reach. Keep your proper footing and balance at all times to enable better control of the compressor in unexpected situations.
5. **NEVER** attempt any complex repairs yourself. If you have a technical problem contact your local CLARKE dealer.
6. **ALWAYS** store the compressor out of reach of children.
7. **ALWAYS** protect your hearing. Ear protection should be worn when operating this compressor and it's associated air tools.
8. **NEVER** direct the air stream at people or animals, as injury may result. Compressed air can cause soft tissue damage and propel dirt and other particles at high speed.
9. **NEVER** insert your fingers or other objects inside the motor housing. **NEVER** operate the compressor without the cover in place.

10. **NEVER** touch hot surfaces. During operation, the motor, connections, compressor body, cylinder head and tubes may get hot. DO NOT touch these until the compressor has cooled down.

GENERAL MACHINE USE AND CARE

1. Prior to use, all operators should become familiar with the instructions in this booklet especially the ON/OFF switch for emergency stopping.
2. **ALWAYS** maintain the compressor with care and keep it clean for best / safest performance.
3. **NEVER** use this compressor if any part is damaged. Have it inspected and repaired by your CLARKE dealer.
4. **NEVER** attempt to modify the air compressor, tank, fittings or attachments in any way. Doing so will invalidate the guarantee and could result in personal injury.
5. **NEVER** abuse the power cable. **NEVER** pull on the cable when removing the plug from the socket, or lift the compressor by the power cable.
6. **ONLY** use extension leads that are of an appropriate power rating and suitable for the work environment. Extension leads must have an earth connection. Inspect the extension lead regularly and replace if damaged.
7. **ONLY USE RECOMMENDED PARTS:** To avoid the risk of bursting, only hoses with a rated pressure of 10 bar, or more should be used. Never attempt to repair damaged hoses.
8. **NEVER** abuse the compressor by standing on it.

AIRLINE HOSES





1. **ALWAYS** ensure that equipment or power tools used in conjunction with the compressor have a safe working pressure exceeding that of the machine.
2. **ALWAYS** keep the air hose away from any attached air tools and ensure that the operator is not restricted by the length of the hose.
3. **ALWAYS** take care when a long air hose is required in the work area as it presents a trip hazard. Coil the hose away as soon as the job is finished.
4. **ALWAYS** avoid kinking or trapping the air hose. **ALWAYS** replace faulty hoses and never attempt a repair if a leak is detected.
5. **NEVER** abuse hoses or connectors. **NEVER** carry an air tool by the hose, or yank it to disconnect from the air supply. Keep hoses away from heat, oil and sharp edges. Check hoses for leaks or worn condition before use and ensure that all connections are secure.
6. **ALWAYS** ensure that the air supply is turned off at the machine outlet and any air pressure vented from within the compressor and any attached equipment when disconnecting air hoses or other equipment.

AIR COMPRESSOR SAFETY INSTRUCTIONS

1. **ONLY USE WITHIN THE RECOMMENDED OPERATING TEMPERATURE RANGE:**
This compressor should only be used in an ambient temperature of between +5°C and +40°C (never at or below freezing temperatures).
2. **NEVER USE AN AIR COMPRESSOR WHICH APPEARS DEFECTIVE OR IS OPERATING ABNORMALLY:** If the compressor operates unusually or makes strange noises, switch off immediately and purge the air reservoir. Arrange repairs with your nearest CLARKE dealer.
3. **BREATHING QUALITY AIR:** This compressor should not be used to supply breathing quality air.
4. **SAFETY VALVE: NEVER** remove or attempt to adjust the safety valve. The maximum pressure is factory set. Keep the safety valve free from paint and other accumulations.
5. **AVOID UNINTENTIONAL STARTING: DO NOT** move the compressor when it is connected to the mains power supply. When connecting the compressor to the power supply make sure the red button on top of the control box is in the **OFF** (down) position.
6. **BEFORE EACH USE CHECK THE COMPRESSOR AND HOSE FOR DAMAGED PARTS: NEVER** use the compressor if it has been damaged in any way. Have the compressor repaired by a qualified service engineer. **DO NOT** use the compressor if the On/Off switch does not operate correctly.
7. **KEEP THE MOTOR AIR VENTS CLEAR:** Wipe regularly to maintain an adequate supply of clean air. Avoid using in dusty conditions.
8. **OPERATE THE COMPRESSOR AT THE CORRECT VOLTAGE:** Make sure that the mains supply voltage is the same as the voltage shown on the label.
9. **ALWAYS** adjust the pressure regulator to the recommended setting for the particular spray gun or air tool being used.
10. When using the compressor for painting:
 - **DO NOT** work in enclosed areas or near naked flames.
 - **ENSURE** that the area in which you are working has good ventilation.
 - Protect your nose and mouth with a suitable face mask.
 - **ALWAYS** check the safety data sheets for substances being sprayed & ensure manufacturer's instructions are followed.
11. **DO NOT USE THIS COMPRESSOR TO INFLATE SMALL, LOW-PRESSURE OBJECTS:**
Items such as children's toys or footballs can explode if over-inflated.
12. **NEVER STOP THE COMPRESSOR BY REMOVING THE PLUG OR SWITCHING OFF AT THE MAINS SUPPLY:** Always use the On/Off switch on the compressor.

SAFETY SYMBOLS

The following safety symbols are shown on the product or it's packaging. Please read all of the safety and operating instructions carefully before using this product.

	Read this instruction booklet carefully before positioning, operating or adjusting the compressor.
	This compressor produces a high sound level during operation. Ear protection should be worn.
	This compressor contains surfaces which may get hot during operation. NEVER operate with the motor housing removed.
	Risk of accidental start-up. The compressor could start automatically in the event of a power cut and subsequent reset. DO NOT carry the compressor while it is connected to the power source, or when the receiver is filled with compressed air.
	Risk of electric shock. The compressor must be disconnected from the mains supply before removing any covers. DO NOT use in a damp environment.

ELECTRICAL CONNECTIONS



WARNING: READ THESE ELECTRICAL SAFETY INSTRUCTIONS THOROUGHLY BEFORE CONNECTING THE PRODUCT TO THE MAINS SUPPLY.

Connect the mains lead to a standard, 230 Volt (50Hz) electrical supply through an approved 13 amp BS 1363 plug, or a suitably fused isolator switch.

If the plug has to be changed because it is not suitable for your socket, or because of damage, it must be removed and a replacement fitted, following the wiring instructions shown below. The old plug must be discarded safely, as insertion into a power socket could cause an electrical hazard.



**WARNING: THE WIRES IN THE POWER CABLE OF THIS PRODUCT ARE COLOURED IN ACCORDANCE WITH THE FOLLOWING CODE:
BLUE = NEUTRAL BROWN = LIVE YELLOW AND GREEN = EARTH**

If the colours of the wires in the power cable do not agree with the markings on the plug:

- The BLUE wire must be connected to the terminal which is marked N or coloured black.
- The BROWN wire must be connected to the terminal which is marked L or coloured red.
- The YELLOW AND GREEN wire must be connected to the terminal which is marked E or \perp or coloured green.

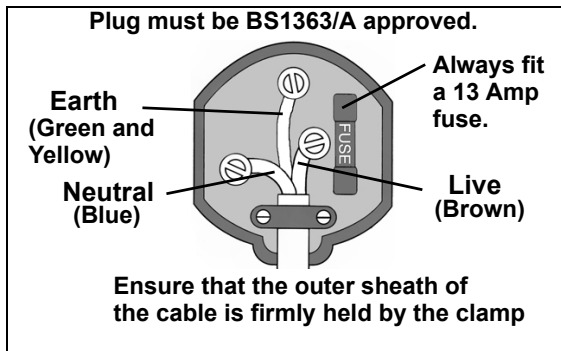

We strongly recommend that this machine is connected to the mains supply through a Residual Current Device (RCD)

If you are not sure, consult a qualified electrician. DO NOT try to do any repairs.

PREPARATION FOR USE

UNPACKING

Take care when lifting the compressor from the packaging and obtain assistance if necessary to avoid personal injury or damage to the machine. Always use the handle and frame.



CAUTION: NEVER TAKE THE WEIGHT OF THE COMPRESSOR BY HOLDING THE PRESSURE CONTROL SWITCH OR OTHER ATTACHED PARTS.

After removing the compressor from its packaging, check that it has not been damaged in transit. Report any damage immediately to the dealer where the item was purchased.

ATTACHING THE WHEELS

Use a suitable spanner to attach the wheels to the compressor.

Use the washers and spring washer in the positions shown.

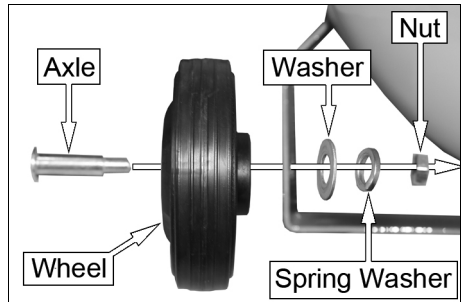

ATTACHING THE SUPPORT FOOT

Fit the support foot into the position shown.



BEFORE USE

Before connecting your compressor to the power supply, check the following:-

- Set the ON/OFF switch to the OFF position (pushed down).
- Ensure the compressor is standing on level ground.
- Make sure that the power supply is suitable.

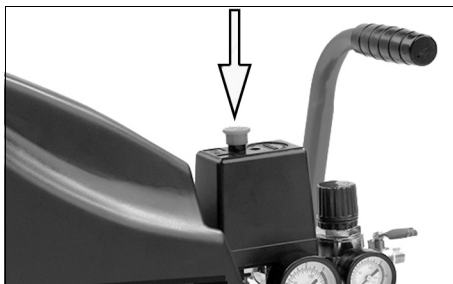

POSITIONING THE COMPRESSOR

This compressor should be positioned on a stable, flat surface.

NOTE: Note: the compressor should not be operated on a steep slope or floor angle of greater than 15°.

If the compressor is placed on a shelf or raised off the ground, it should be secured appropriately to prevent it from falling off during use.

Do not cover the compressor. Always position it with good ventilation.

MOVING THE COMPRESSOR

When moving the compressor;

- Always use the handle wherever possible.
- Do not lift by (or place a strain on) the airline fittings or hoses.
- Take care to avoid damaging the valves or fittings.
- Ensure it is switched off and disconnected from the power supply.

OPERATION

If the compressor has not been used for more than 24 hours, open the drain valve on the bottom of the reservoir and drain any condensate which has collected. See page 12.

ATTACHING AIR TOOLS



WARNING: BEFORE CONNECTING AIR TOOLS, MAKE SURE THAT YOU READ THE INSTRUCTIONS SUPPLIED WITH THE TOOL, ALSO ENSURE THAT THE AIR TOOL IS SUITABLE FOR USE WITH THE COMPRESSOR AND HOSE SPECIFICATIONS.

1. Attach the air hose to the ¼" BSP outlet valve.
2. Attach the tool to the end of the air hose.

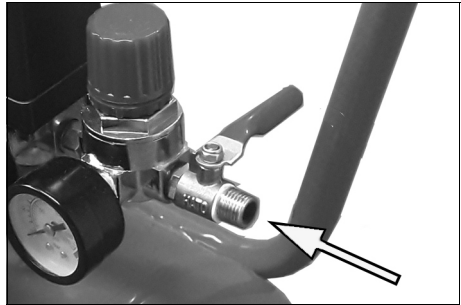

3. Turn the outlet valve handle to the on position.

NOTE: The outlet valve is shown without the air hose fitted for clarity.

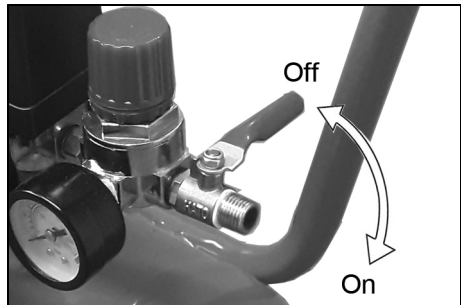

TURNING THE COMPRESSOR ON

1. Plug the compressor into the power supply.
2. Lift the On/Off button.
 - The compressor will operate until the reservoir is fully pressurised. It will then shut down.
 - The compressor will start up again when the pressure in the reservoir decreases.

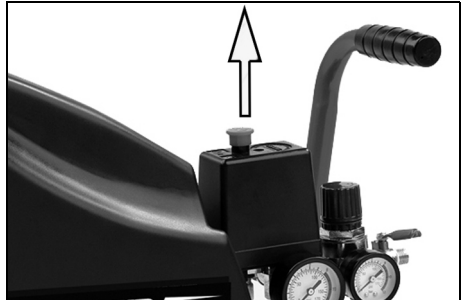

SET THE OUTPUT PRESSURE

1. Use the pressure regulator to set the output pressure of the left hand outlet valve.
 - Turn clockwise to increase the pressure.
 - Turn counterclockwise to decrease the pressure.

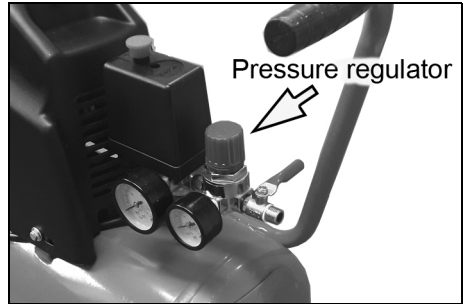

GAUGES

1. The reservoir pressure gauge shows the current pressure in the reservoir.
2. The outlet pressure gauge shows the 'user set' outlet pressure. This can be adjusted as shown above.

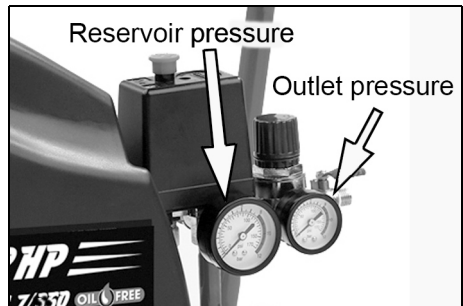

REMOVING TOOLS FROM THE AIR HOSE



WARNING: ALWAYS SET THE PRESSURE REGULATOR TO ZERO BEFORE YOU REMOVE OR REPLACE A TOOL.

1. Push down on the On/Off button to stop the compressor.

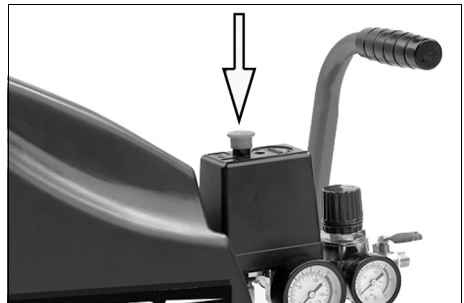

2. Turn the outlet valve handle to the off position.
3. Operate the tool to depressurise the air hose.
4. Disconnect the tool from the hose.

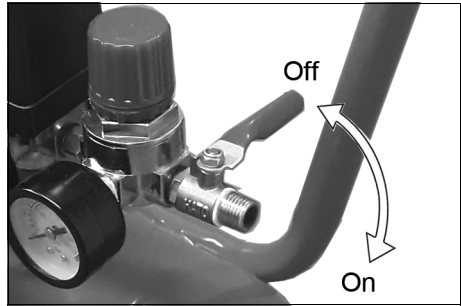

TURNING THE COMPRESSOR OFF

1. Follow steps 1-3 in "Removing Tools from the Air Hose" above.
2. Disconnect the compressor from the power supply.
3. Slowly open the outlet valve to depressurise the reservoir.
 - You will hear a hissing sound as the reservoir depressurises.
 - Do not leave the compressor unattended if the reservoir is pressurised.

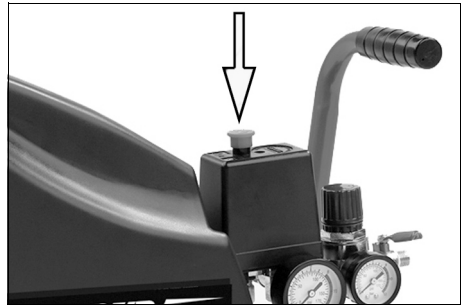

DRAINING THE RESERVOIR



CAUTION: YOU MUST DRAIN THE RESERVOIR AFTER EACH DAYS USE AND BEFORE YOU PUT YOUR COMPRESSOR INTO STORAGE.

1. Turn the compressor off and disconnect from the power supply.
2. Put a container below the drain valve to collect the condensate.
3. Open the drain valve slowly.
 - Condensation will drain from the reservoir.
4. Close the drain valve when the reservoir has fully drained.

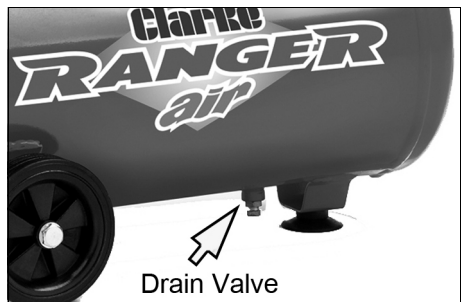

RESET BUTTON

This compressor has a thermal overload device.

If the motor gets too hot, the thermal overload device cuts the power which prevents damage to the motor.

If the thermal overload device operates, let the motor cool down for 5 minutes and push the reset button.

If you start the compressor and the overload cutout operates again, stop the compressor and disconnect from the power supply and have your compressor examined by a qualified service agent.

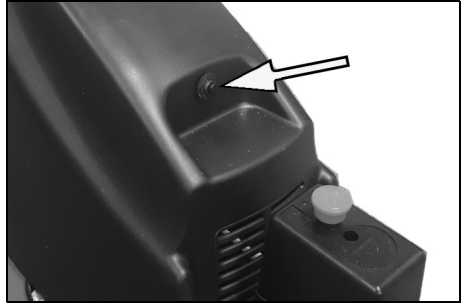

MAINTENANCE

CAUTION: ALWAYS DISCONNECT FROM THE POWER SUPPLY BEFORE CARRYING OUT ANY MAINTENANCE

DRAINING THE RESERVOIR

After use, always open the drain valve to make sure that any condensate is drained off.

CHECKING THE NON-RETURN VALVE

If the reservoir pressure decreases for no apparent reason it is possible that the non-return valve is leaking. To check:

1. With the reservoir is not under pressure and the compressor switched OFF, examine the non-return valve and replace the gasket and valve if necessary.

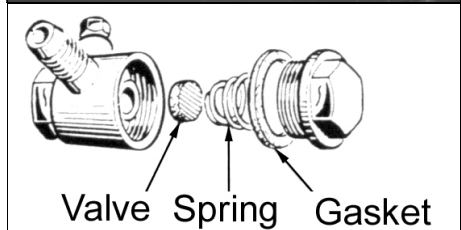
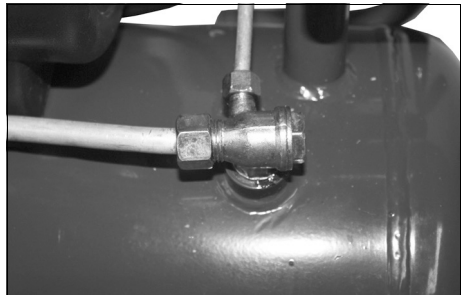

ENVIRONMENTAL PROTECTION



Recycle unwanted materials instead of disposing of them as waste. All tools, accessories and packaging should be sorted and taken to a recycling centre for disposal in a manner compatible with the environment.

By purchasing this product, the customer is taking on the obligation to deal with its safe disposal in accordance with the Waste Electrical and Electronic Equipment (WEEE).

In effect, this means that this product must not be disposed of with general household waste. It must be disposed of according to the laws governing Waste Electrical and Electronic Equipment (WEEE) at a recognised disposal facility. If disposing of this product or any damaged components, do not dispose of with general waste. This product contains valuable raw materials. Metal products should be taken to your local civic amenity site for recycling of metal products. Should any components become completely unserviceable and require disposal plastic and metal should be disposed of according to local regulations.

TROUBLESHOOTING



CAUTION: DO NOT TRY TO REPAIR OR ADJUST THIS COMPRESSOR IF YOU ARE UNCERTAIN. IF YOU HAVE ANY QUERIES, CONTACT YOUR DEALER.

PROBLEM	PROBABLE CAUSE	REMEDY
The compressor has stopped and does not start.	Bad electrical connection	1. Check electrical connections. 2. Clean and tighten if necessary.
	Overload cutout switch has tripped.	1. Switch off and wait approx 5 minutes. 2. Press the reset button and switch on again.
	Motor windings burnt out.	1. Contact your CLARKE dealer for a replacement motor.
The compressor does not reach the set pressure and overheats easily.	Compressor head gasket blown or valve broken.	1. Return the machine to your nearest CLARKE dealer.
Compressor does not start.	The reservoir has already fully pressurised.	1. Open drain valve to expel air. Compressor should start again when pressure reduces.
Air leaking from the non-return valve when the compressor is not running.	Faulty non-return valve.	1. Drain receiver completely of air. 2. Remove the valve end plug. 3. Carefully clean the valve seat and the gasket 4. Reassemble.
Air pressure from the regulator will not adjust.	The diaphragm within the regulator body is broken.	1. Replace regulator
Compressor is very noisy and makes a metallic knocking sound.	Compressor damaged and needs overhaul.	1. Return the machine to your nearest CLARKE dealer.

COMPONENT PARTS

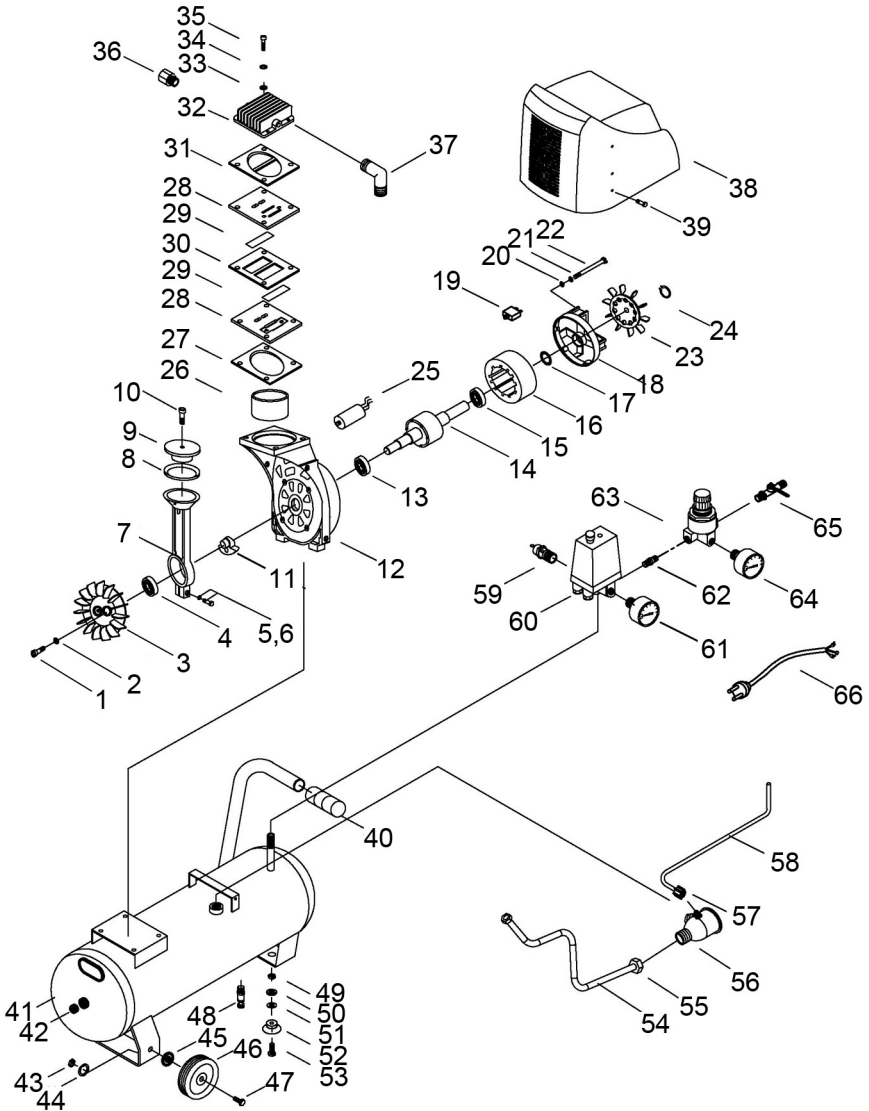

COMPONENT PARTS

NO	DESCRIPTION
1	Bolt
2	Washer
3	Fan
4	Bearing
5	Washer
6	Bolt
7	Connecting rod
8	Seal cup
9	Pressplate
10	Bolt
11	Crankshaft
12	Crankcase
13	Bearing
14	Rotor
15	Bearing
16	Stator
17	Wave gasket
18	Bearing seat
19	Overload protector
20	Flat washer
21	Spring washer
22	Long bolt
23	Fan
24	Pin clip
25	Capacitor
26	Cylinder
27	Valve plate gasket
28	Valve plate
29	Valve reed
30	Aluminium gasket
31	Head cover gasket
32	Head cover
33	Flat Washer

NO	DESCRIPTION
34	Spring washer
35	Bolt
36	Air filter
37	Elbow
38	Shroud
39	Bolt
40	Handle cover
41	Tank
42	Checking hole plug
43	Hex nut
44	Spring washer
45	Flat washer
46	Wheel
47	Bolt
48	Drain valve
49	Nut
50	Spring washer
51	Flat washer
52	Foot
53	Bolt
54	Exhaust pipe
55	Hex nut
56	Check valve
57	Discharge pipe nut
58	Discharge pipe
59	Safety valve
60	Pressure switch
61	Pressure gauge(50mm)
62	Connector
63	Regulator
64	Pressure gauge(40mm)
65	Air tap
66	Power cable

DECLARATION OF CONFORMITY



Clarke[®]
INTERNATIONAL

Fitzwilliam Hall, Fitzwilliam Place, Dublin 2

DECLARATION OF CONFORMITY

This is an important document and should be retained.

Product Description: 24L Air compressor
Model number(s): Ranger 7/260
Serial / batch Number: 2242030
Date of Issue: 14/05/2021
Notified Body: TÜV SÜD Industrie Service GmbH
Westendstraße 199
80686 MÜNCHEN
Germany

Technical Documentation Holder: Clarke International
Fitzwilliam Hall,
Fitzwilliam Place,
Dublin 2

Conformity Assessment Procedure: to 2000/14/EC Annex VI
Manufacturer: Clarke International
Noise Related Value: 1.5 kW
Measured Sound Power Level: 94 dB
Guaranteed Sound Power Level: 96 dB

DECLARATION OF CONFORMITY



Clarke[®]
INTERNATIONAL

Fitzwilliam Hall, Fitzwilliam Place, Dublin 2

DECLARATION OF CONFORMITY

This is an important document and should be retained.

We hereby declare that this product(s) complies with the following directive(s):

- 2006/42/EC Machinery Directive.*
- 2014/30/EU Electromagnetic Compatibility Directive.*
- 2011/65/EU Restriction of Hazardous Substances (amended by (EU) 2015/863).*
- 2014/29/EU Simple Pressure Vessel Directive*
- 2000/14/EC Noise Emissions Directive, (amended by 2005/88/EC).*

The following standards have been applied to the product(s):

- EN 1012-1:2010, EN 60204-1:2006+A1:2009, EN 61000-3-2:2014, EN 61000-3-11:2000,*
- EN 55014-1:2017, EN 55014-2:2015.*

The technical documentation required to demonstrate that the product(s) meet(s) the requirement(s) of the aforementioned directive(s) has been compiled and is available for inspection by the relevant enforcement authorities.

The CE mark was first applied in: 2021

Signed:

J.A. Clarke
Director

A SELECTION FROM THE VAST RANGE OF

Clarke®

QUALITY PRODUCTS



AIR COMPRESSORS

From DIY to industrial, Plus air tools, spray guns and accessories.

GENERATORS

Prime duty or emergency standby for business, home and leisure.

POWER WASHERS

Hot and cold, electric and engine driven - we have what you need

WELDERS

Mig, Arc, Tig and Spot. From DIY to auto/industrial.

METALWORKING

Drills, grinders and saws for DIY and professional use.

WOODWORKING

Saws, sanders, lathes, mortisers and dust extraction.

HYDRAULICS

Cranes, body repair kits, transmission jacks for all types of workshop use.

WATER PUMPS

Submersible, electric and engine driven for DIY, agriculture and industry.

POWER TOOLS

Angle grinders, cordless drill sets, saws and sanders.

STARTERS/CHARGERS

All sizes for car and commercial use.



PARTS & SERVICE: 0208 988 7400

Parts Enquiries
Parts@clarkeinternational.com

Servicing & Technical Enquiries
Service@clarkeinternational.com

SALES: UK 01992 565333 or Export 00 44 (0)1992 565335

Clarke INTERNATIONAL Hemnall Street, Epping, Essex CM16 4LG
www.clarkeinternational.com